

Circular Transportation in the 21st Century (without the “Beautiful” Counterweight!)

Adrian M. Godwin BSc DMS MCIM CEng MIET

Lerch Bates, United Kingdom

Key Words: Linear Motors, Multi-Mobile Systems, Skytrak, Vertical Transportation, Improvements in Passenger Handling

ABSTRACT

This article is a summary of highlights from a paper presented in late 2009 at the New Civil Engineer’s Conference held in London called “Engineering Design for Tall Buildings” entitled “Vertical Transportation, Maximising Core Efficiency - New Concepts”.

There has been much talk over the past thirty years or more about the prospects of having multiple passenger cabins travelling in one shaft. Why? Because of the innate efficiency gains, especially for very tall buildings, that would follow such a quantum leap in passenger handling capacity for any given lift shaft. Of course, to even attempt this would require one to dispense with ropes as well as the “beautiful” counterweight. The attraction of circular vertical transportation is that it provides the quantum leap in passenger handling capacity without the mechanical complexity of moving cabins horizontally as would otherwise be the case for normal vertical systems.

1. INTRODUCTION

It is only when one considers dispensing with the balance weight that one realises how heavily reliant upon this simple device the basic design of most traction lifts are. Some of the many advantages of the “beautiful” counterweight include:

1. Minimising the energy input required to hoist a given load.
2. Minimising deceleration forces especially when “emergency” stops are made.
3. Displacing the local structural loads of the cabin, usually to high level.
4. Simplifying emergency release operations.

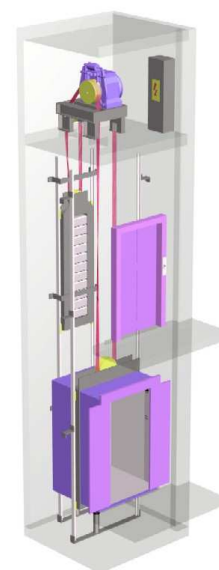

Figure 1 shows typical traction lift with counterweight

5. The large masses significantly contribute to the smoothing of the passenger ride quality.

To reinforce the many advantages of using a counterweight let us imagine for a moment some of the implications of a decision to remove the ropes and the “beautiful” counterweight:

1. Probable increase in local shaft structural loads of approximately 6-7 times
2. Probable increase in drive motor power by approximately 6-7 times
3. Increase in energy losses of approximately 6-7 times
4. Transmission of power and data to/from the lift car without trailing cables
5. Increase in the braking force required from the fail-safe brake
6. Manual release of the fail-safe brake for passenger release not practical
7. Serious problem of dealing with emergency stopping in either direction
8. Control of headway between cabins and capability to take cabins off the track

2. INCREASING BUILDING EFFICIENCY

As most consultants and lift companies will attest to it is the goal of building designers to continually improve building efficiency i.e. the net to gross built floor areas such as to increase the proportion of that more valuable part of the building which is the “rentable” or “saleable” element.

In recent years’ consultants and designers’ attention has been focussed upon such techniques as:

- Use of double deck lifts and 3-D “Double Deck Destination” Control
- Use of Shuttle & Local Goods Lift Services similar to Passenger Lifts
- Time Sharing of Lifts to achieve 24 hour utilisation (multi-use towers)
- “Twin Lift” solutions for passenger and goods lift service
- Combining Different Uses of Decks/ Entrances at Different Times

All of these are being pursued for one simple expedient i.e. minimisation of the space taken out of the building by the lifts.

But let’s look briefly at the approximate scale of the core space savings that might be achieved if we could arrange for multiple cabins to travel in a single shaft. Supposing a conventional 40 floor high rise office building needed four groups of six single deck

passenger lifts @ 1600kg at speeds between 2.5 and 6.0m/s in order to obtain 15% 5-minute handling capacity with an average interval of 30s. At the main lobby we would have lift shafts and lobbies occupying approximately 400 sq m perhaps looking something like this in plan:

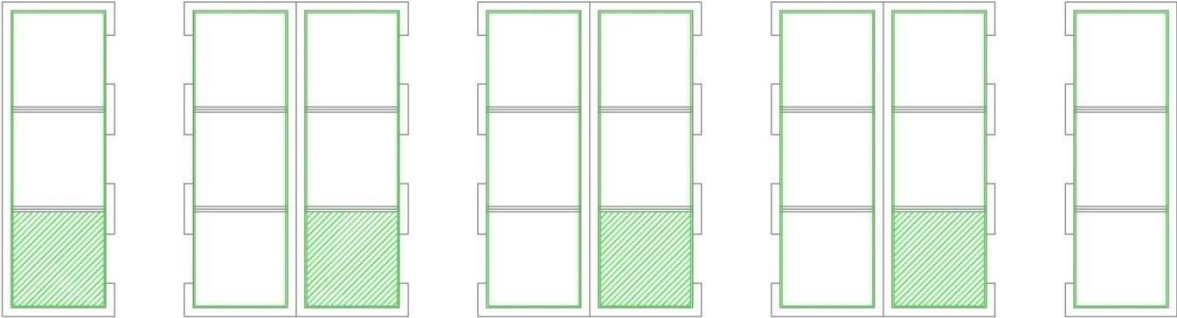

Supposing one passenger lift @ 1600kg at 6.0m/s appeared in one shaft travelling “up” every 30s. At the main lobby we would have a revised footprint of lift shafts and lobbies that looked like this:



The fifth shaft, shown in orange colour, is for “down” travelling passengers in “up peak”. Finally, because of the very high handling capacity of each shaft we might add in an extra shaft, shown in blue, for redundancy to ensure overall system performance at all times, producing a footprint something like this.

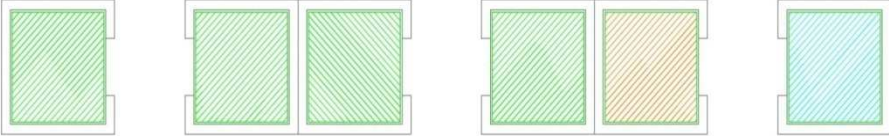

Instead of the whole core taking up the equivalent of 36 shafts at the ground floor the new solution takes up the equivalent of 9 shafts or 100 sq m i.e. 25% of the conventional solution. Building wide the conventional solution might take out the equivalent of 10,000 sq m whereas the new solution might take out 4,000 sq m. That’s nominally 60% more efficient than a conventional single deck lift solution. A significant part of the additional capital value released by the new solution, due to the additional rentable area gained, could be applied to a new more sophisticated vertical transportation system.

Whereas the conventional solution needed 24 lifts in 24 lift shafts the new solution needs only six shafts therefore immediately the “lift service” within each shaft can cost four times what the conventional lifts did without adding any capital cost. Perhaps the new vertical transportation system could potentially cost ten times more per shaft than each conventional lift as one applies some of the capital value gained from the efficiency

savings to the new vertical transportation system. Overall the new solution would still represent additional value to the final development.

The taller and larger the building the more pronounced the efficiency savings and the more scope there is to expend monies on a more advanced vertical transportation system. Well, in simplistic terms, that's the imperative for wanting to be able to deliver multiple cabins travelling in one shaft and the economic rationale.

3.0 APPLICATION OF LINEAR MOTORS FOR MULTI-MOBILE SYSTEMS

Pretty well everyone realises however that once one moves beyond having two cabins in one shaft you are almost certainly talking about the application of linear motors along the entire length of travel of the cabs that would, in theory, be moving up or down each shaft.

That said, today, most of the key components necessary have been identified and are available at commercially viable costs. Examples are:

1. Linear Motors – Retarders - Generators
2. Rare Earth Permanent Magnets, Super Capacitors
3. Power Inverters and Fast Response High Efficiency Sensor-less Drives
4. Control Software and Data-logging
5. Security and Monitoring Systems
6. Transportation Control Software (SIL4 Processors)
7. Wireless Signalling and Communications
8. Lightweight Materials for Cabin Structure

Research has continued apace over recent years and readers interested in some of the more technical aspects such as the progress of the application of “long stator linear motors to a multi mobile system” may like to look at papers that have been presented in recent years from the EPFL (Ecole Polytechnique Federale de Lausanne) in Switzerland which indicates direct links with Schindler and their R&D work in this area.

Some of the key challenges where adequate solutions have to be found and satisfactorily proven include

- Free fall under gravity when the brake is released
- The trapping of passengers in cabins on the track during emergency stopping
- The trapping of passengers in cabins on the track when power is lost
- The consequence of power failure in the “up” direction at high speed etc.
- Maintaining a smoothness of ride that characterises the best traditional elevator

4.0 A NOVEL INVENTION

In reviewing some of the papers compiled by the EPFL it appears that the speed of some of the systems being considered might be low enough such that an emergency stop in the up direction may not cause too much passenger distress however at higher speed, and for more practical applications, this technical challenge still exists. A recent invention by Mike Godwin (patent pending) described here may represent the solution to that last item.

Working with specialist companies from China to Belgium and from Spain to Switzerland Mike Godwin has arrived at the design of a prototype cabin able to move not only horizontally and vertically but through a curved trajectory as well. The reason for targeting the curved trajectory solution was the realisation that such a vertical transportation system would offer architects and building designers not only greater efficiency but a new “degree of freedom” for the shapes and designs of buildings of the future. It also ultimately yields the very special circular vertical transportation solution described in this paper. For more information and a short video see <http://www.lerchbates.eu/index.php/uncategorized/skytrak/>

The following diagrams illustrate the concept of how one or more cabins might travel on a track and how some of the safety solutions would operate.

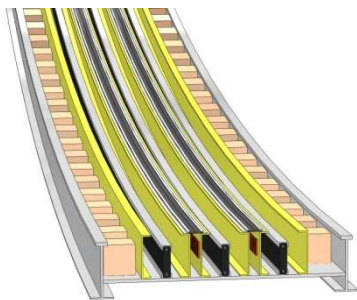

Figure 2 shows the main track structure comprising three double sided linear motor stator sections (black), twin magnet tracks for not only safety retarding under gravity and on-board power generation but importantly deceleration control during emergency “up” stopping. Track side power switching devices are also shown

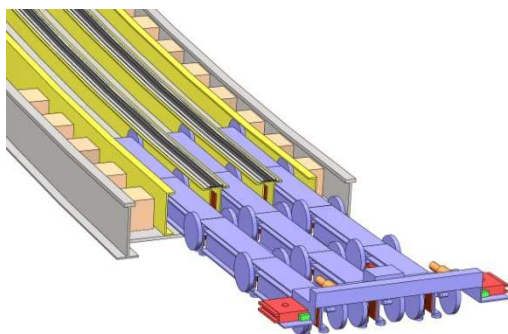

Figure 3 shows the main drive moving magnet assembly (blue) with articulated sections, guide wheels and brakes (red)

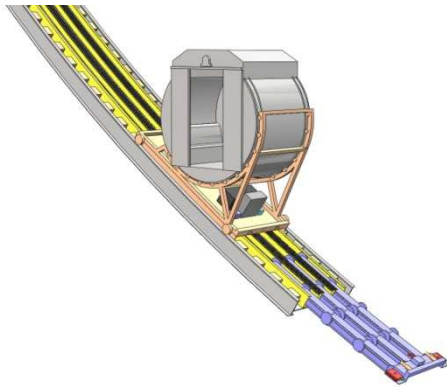

Figure 4 shows the passenger carrying assembly as a lightweight structure of approximately 3m diameter in the form of a drum (grey) which can rotate to remain vertical at all times. The whole cabin has a low centre of gravity. The retarders, attached to the cabin, engage the twin magnet tracks under the main cabin assembly so as to avoid passenger entrapment by allowing the cabin to return to the nearest floor under gravity at low speed. Wireless data transmission, batteries and a super capacitor pack are also mounted on board.

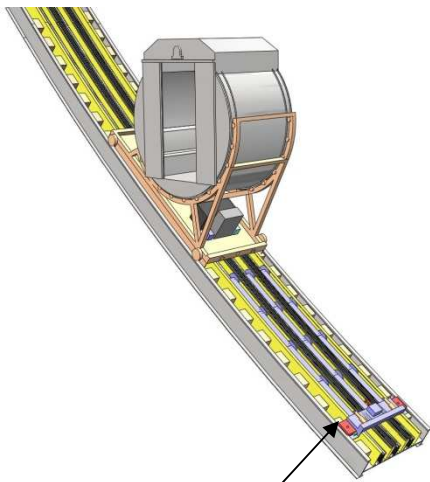
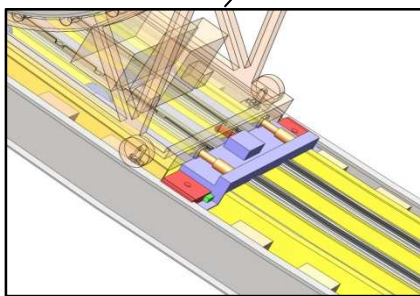

Figure 5 when stopping at high speed e.g. 6.0 m/s in the “up” direction the main drive assembly instantly more or less stops using its failsafe brakes whilst an inertia latch permits the cabin assembly to become detached from the main drive assembly and continues to travel forward under its own momentum. To assist this momentum and provide a comfortable slowdown, taking perhaps 3s or so, instant power from the on board super capacitor pack is connected to the retarders which then become motors.



After this controlled deceleration the cabin then rolls back, with the retarders reconnected with their tuning capacitors, at controlled speed to rejoin the main drive assembly and thence to continue its safe descent downwards at low speed to the nearest floor served or the lowest part of the track system for release of passengers

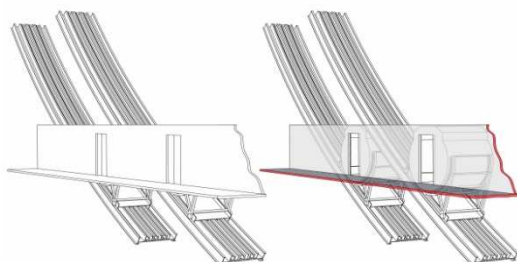

Figure 6 shows how existing standard fire-rated lift landing arrangements can be used for passengers entering and alighting from the cabins

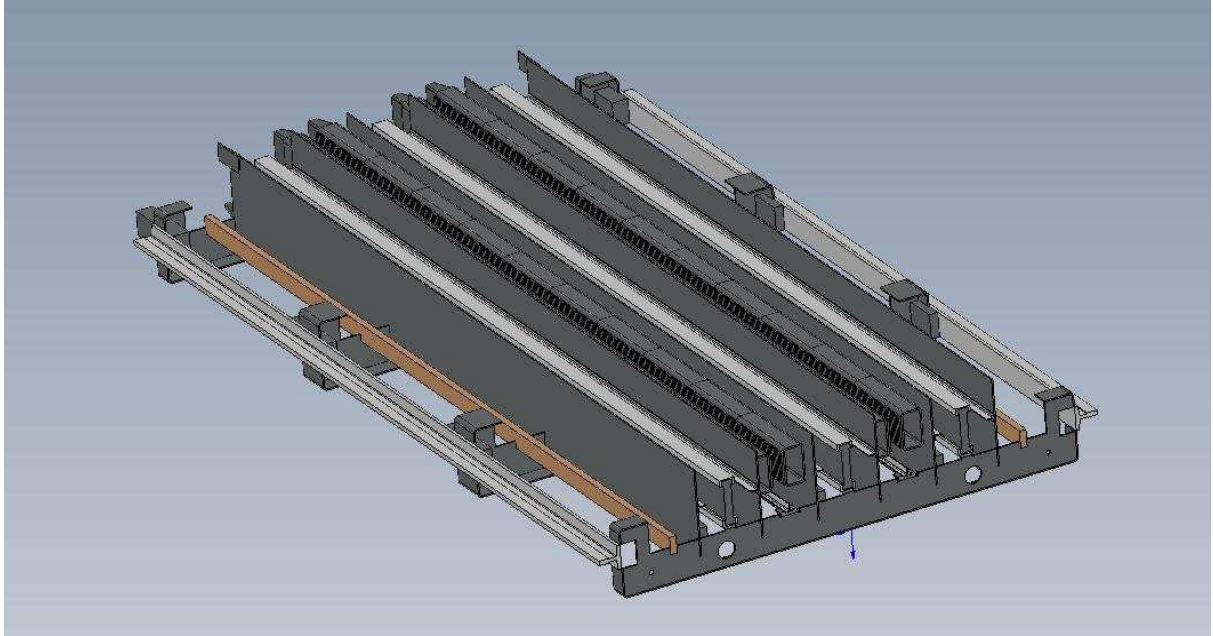

Figure 7 shows a possible arrangement of the track elements and structure to be built in 5m straight or curved sections

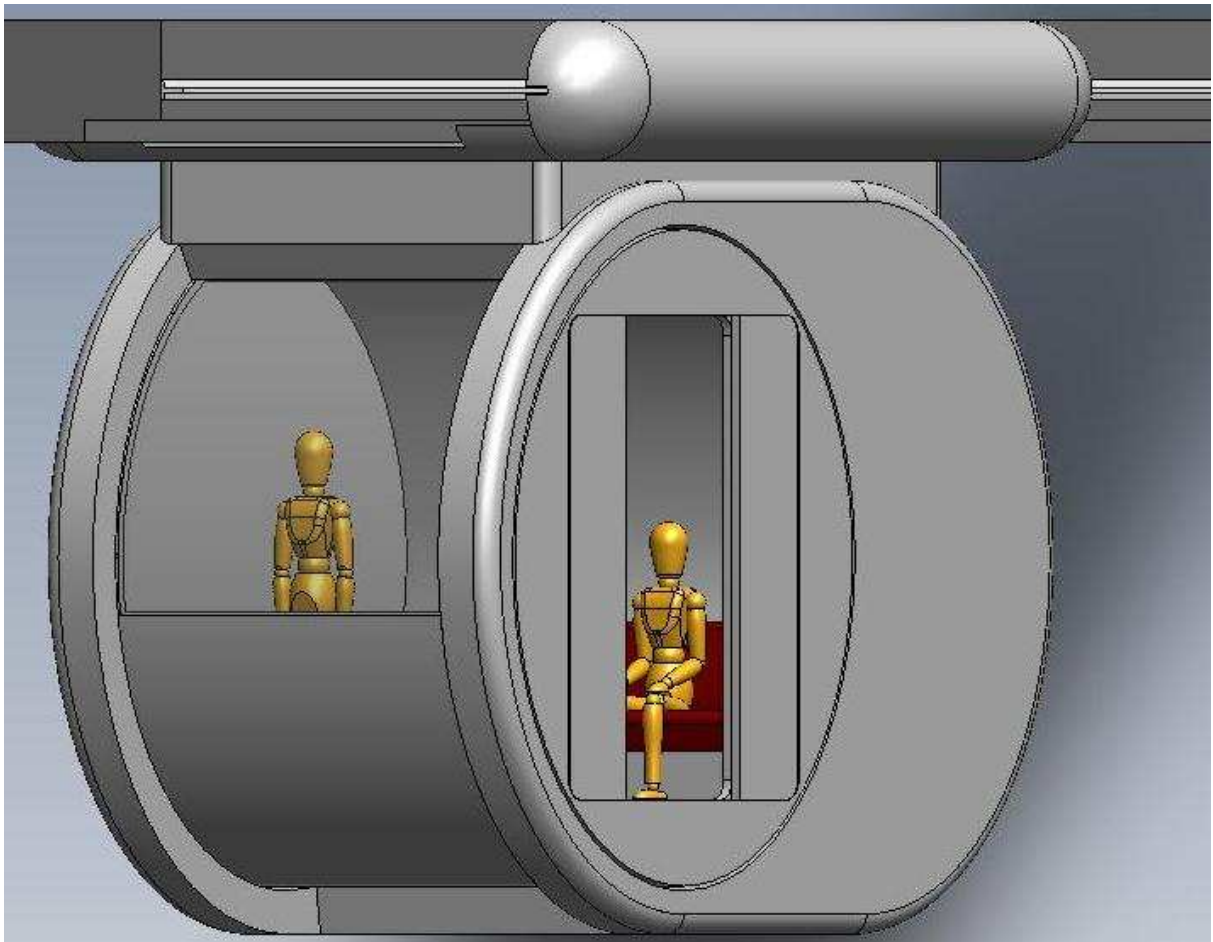

Figure 8 shows the lightweight “Skytrak” passenger cabin which can accommodate both standing and seated passengers as well as two curved windows for “scenic” applications

5.0 CONCLUSIONS

The invention of circular transportation will offer architects a new “degree of freedom” for building shapes and configurations. It offers all the advantages of multiple cabins travelling in one shaft without the increased mechanical complexity of transferring cabins horizontally or on and off tracks etc. Being simple and building on at least some aspects of current lift engineering it is likely to provide a more reliable service. Most importantly the ride quality should be substantially as a traditional elevator with a “beautiful counterweight”!

As a result of this recent feasibility study and accompanying inventions there is now a body of work available, which was begun by Mike Godwin in 1976, to realise this important development in vertical transportation. Historically the name “Skytrak” was coined in 1986 at the inauguration of the IAEE, within a paper presented by Mike Godwin, describing the opportunities and challenges of applying linear motors to vertical transportation. Indeed, it would now be appropriate to construct a prototype to ensure passenger ride quality can be achieved and for the necessary safety type testing and certification to be obtained. Therefore let us ask architects and building designers to dream about a new generation of 21st century buildings wherein these new possibilities for vertical transportation will dominate their inherent design and use.....

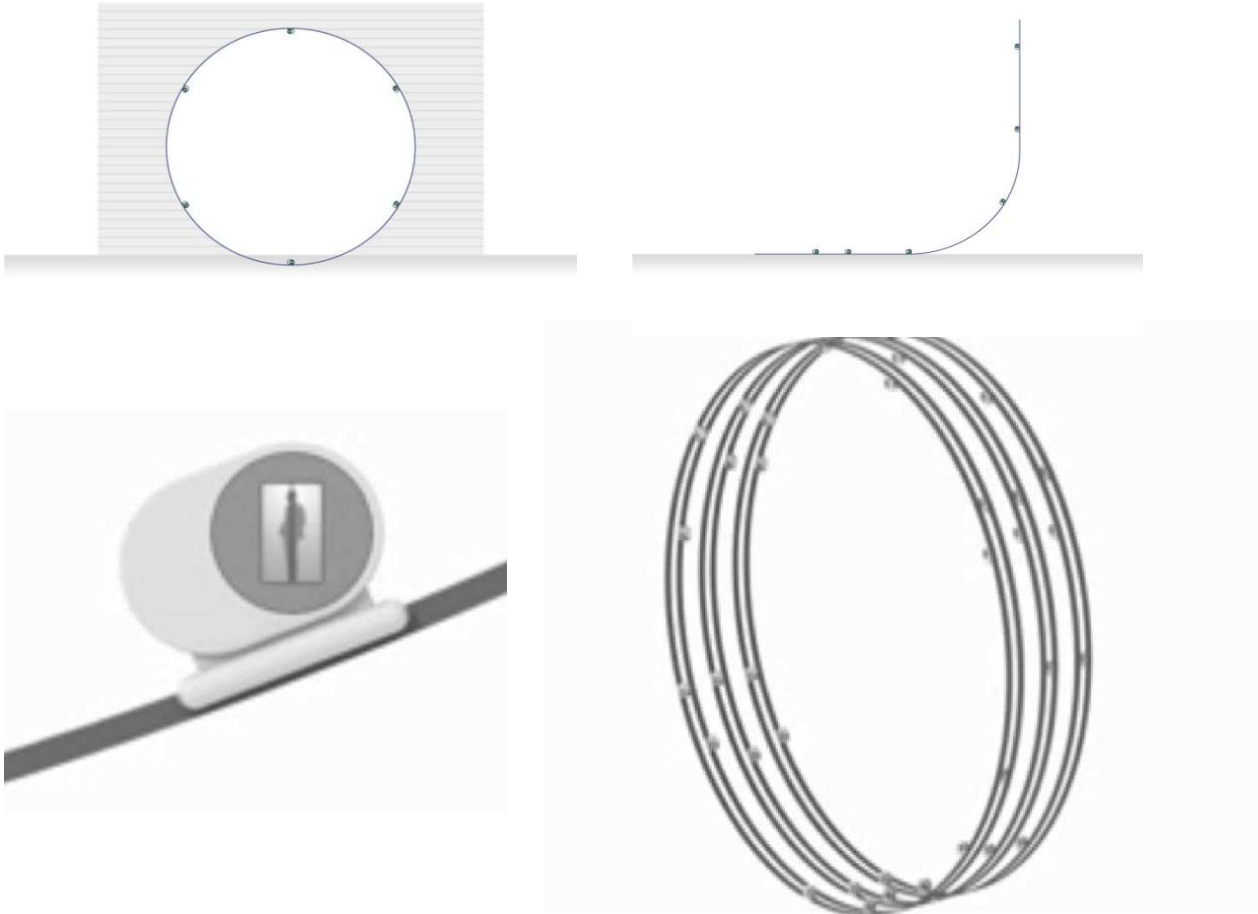

Figure 9 New shapes of buildings are now possible using the “Skytrak” circular transportation solution operating on 360 degree oriented tracks with multiple cabins